

Practical Computerized Home Automation

BRUCE MOMJIAN,
ENTERPRISEDB

July, 2009

***Enterprise*DB™**

Abstract

Home automation is computer control of home devices, typically electrical. Using inexpensive hardware and open source software, it is possible to programmatically control many devices in your home, providing ease and enjoyment for your family.

<http://momjian.us/presentations>

Non-Programmatic Automation

- Timers
- Clapper
- Dawn/Dusk Sensors
- Motion Sensors

Programmatic Automation

- Device behavior can be combined
- No distance limitations
- Activity detection
- Fully programmable / scriptable
- Access to external data

How Is This Possible?

Home Networks

- Wired telephone
- Cordless telephone (900MHz, 2.4GHz, 5.8 GHz, 1.9GHz)
- Wired local area network (Ethernet)
- Wireless local area network (802.11)
- **Electrical**

Adding A Signal

Complementary Pair Data

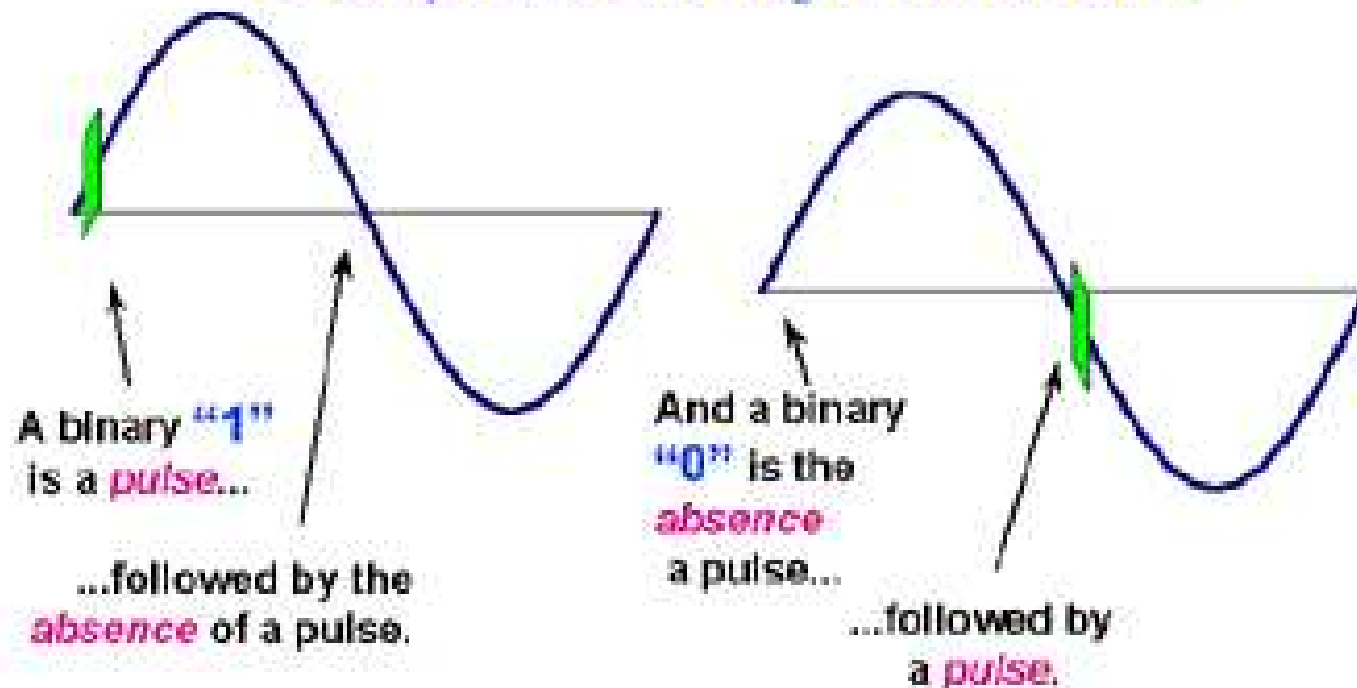
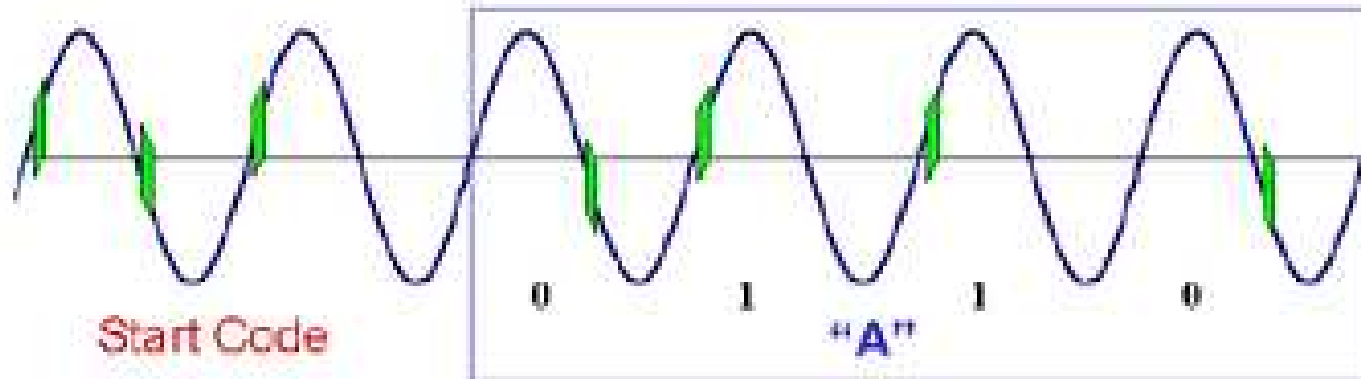

Figure 2

Multiple Bits

Immediately after a "Start Code",
a "Letter Code" is sent. (4 cycles)



A = 0110	E = 0001	I = 0111	M = 0000
B = 1110	F = 1001	J = 1111	N = 1000
C = 0010	G = 0101	K = 0011	O = 0100
D = 1010	H = 1101	L = 1011	P = 1100

Figure 3

Oscilloscope Showing Zero

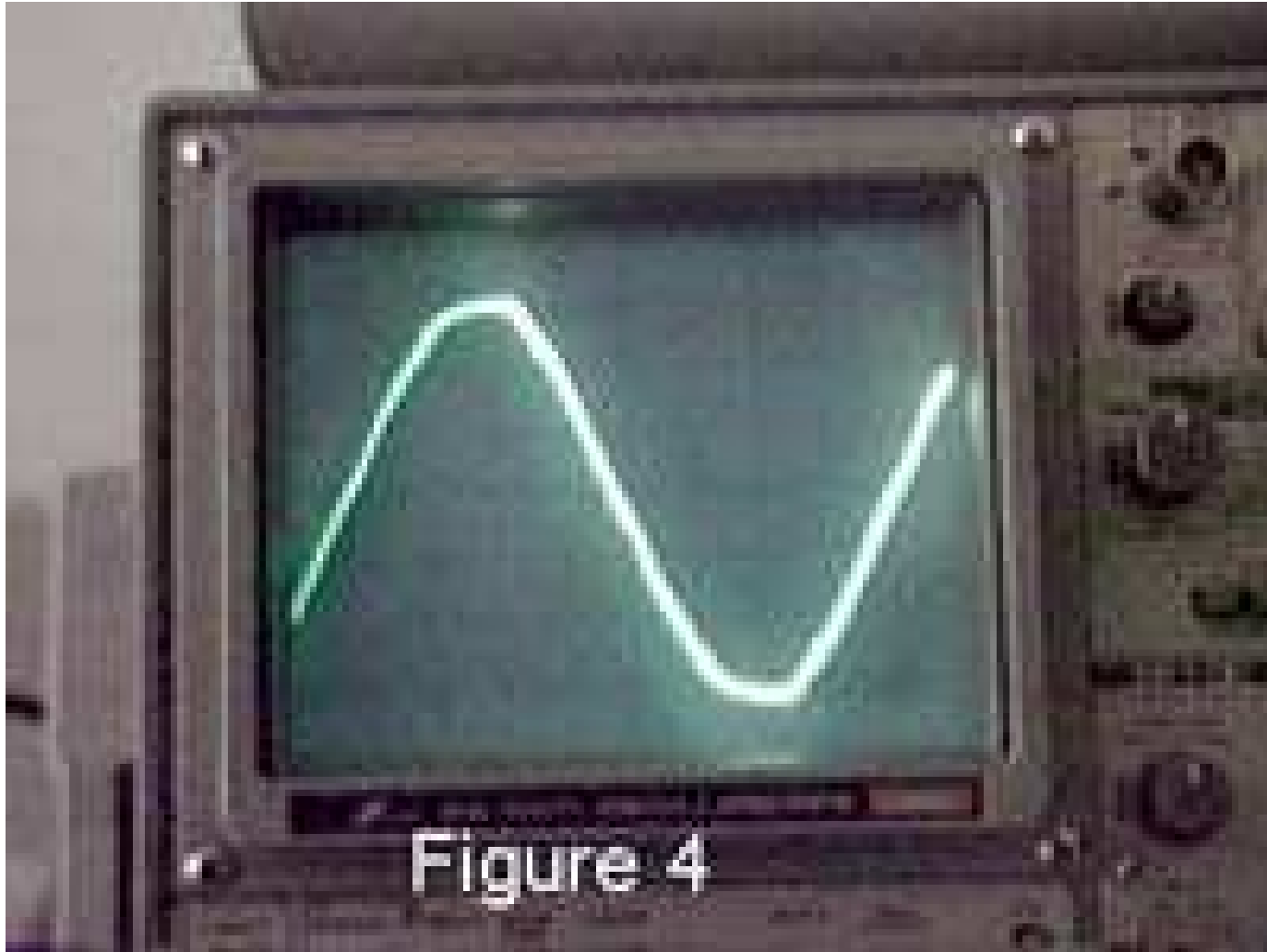

Oscilloscope Showing One

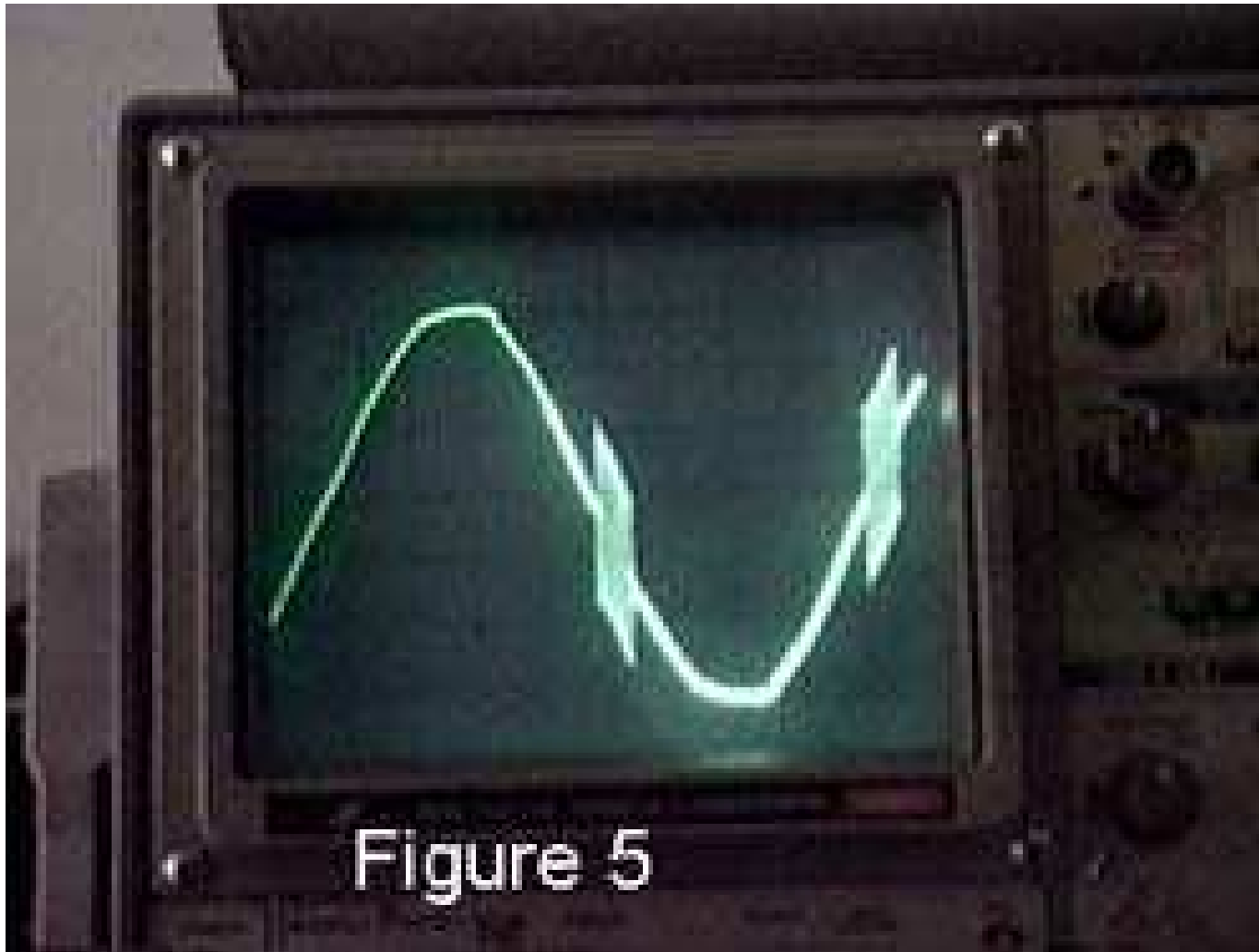

The X10 Standard

X10 is an international and open industry standard for communication among electronic devices used for home automation.

- Designed in 1975 by Pico Electronics of Glenrothes, Scotland
- Uses a 120 kHz carrier transmitted as bursts during the relatively quiet zero crossings of the 60 Hz AC alternating current waveform
- One bit is transmitted per zero crossing
- 120 bits per second transmission rate
- 256 device maximum
- 16 house codes, A-P; 16 devices per house code, 1-16

[http://en.wikipedia.org/wiki/X10_\(industry_standard\)](http://en.wikipedia.org/wiki/X10_(industry_standard))

X10 Protocol

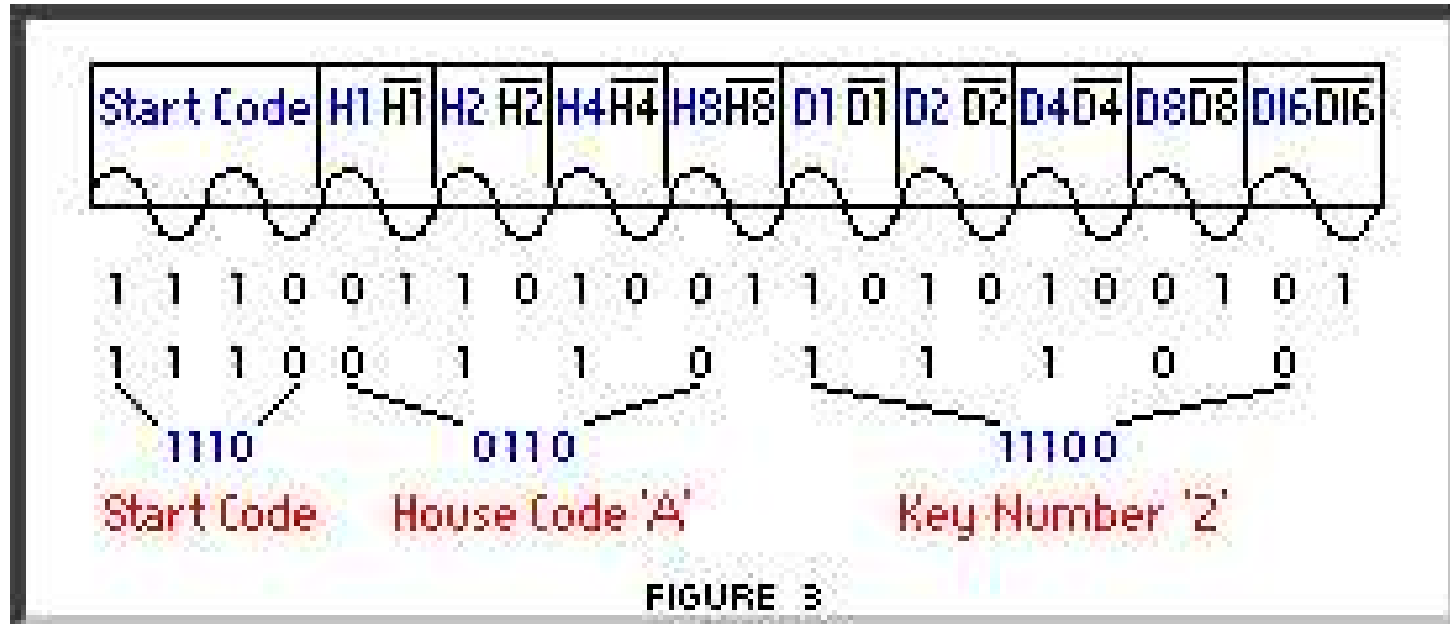

<http://www.x10.com/support/technology1.htm> and following

X10 Protocol

HOUSE CODES					KEY CODES					
	H1	H2	H4	H8		D1	D2	D4	D8	D16
A	0	1	1	0	1	0	1	1	0	0
B	1	1	1	0	2	1	1	1	0	0
C	0	0	1	0	3	0	0	1	0	0
D	1	0	1	0	4	1	0	1	0	0
E	0	0	0	1	5	0	0	0	1	0
F	1	0	0	1	6	1	0	0	1	0
G	0	1	0	1	7	0	1	0	1	0
H	1	1	0	1	8	1	1	0	1	0
I	0	1	1	1	9	0	1	1	1	0
J	1	1	1	1	10	1	1	1	1	0
K	0	0	1	1	11	0	0	1	1	0
L	1	0	1	1	12	1	0	1	1	0
M	0	0	0	0	13	0	0	0	0	0
N	1	0	0	0	14	1	0	0	0	0
O	0	1	0	0	15	0	1	0	0	0
P	1	1	0	0	16	1	1	0	0	0
			All Units Off			0	0	0	0	1
			All Lights On			0	0	0	1	1
			On			0	0	1	0	1
			Off			0	0	1	1	1
			Dim			0	1	0	0	1
			Bright			0	1	0	1	1
			All Lights Off			0	1	1	0	1
			Extended Code			0	1	1	1	1
			Hail Request			1	0	0	0	1 ^①
			Hail Acknowledge			1	0	0	1	1
			Pre-Set Dim			1	0	1	X	1 ^②
			Extended Data (analog)			1	1	0	0	1 ^③
			Status-on			1	1	0	1	1
			Status-off			1	1	1	0	1
			Status Request			1	1	1	1	1

FIGURE 4

X10 Limitations

- Requires 0.75 seconds to transmit a command
- Poor propagation in split-phase electricity distribution
- Affected by line noise from other devices
- Affected by X10 signals from other buildings

The Split-Phase Electricity Distribution Problem

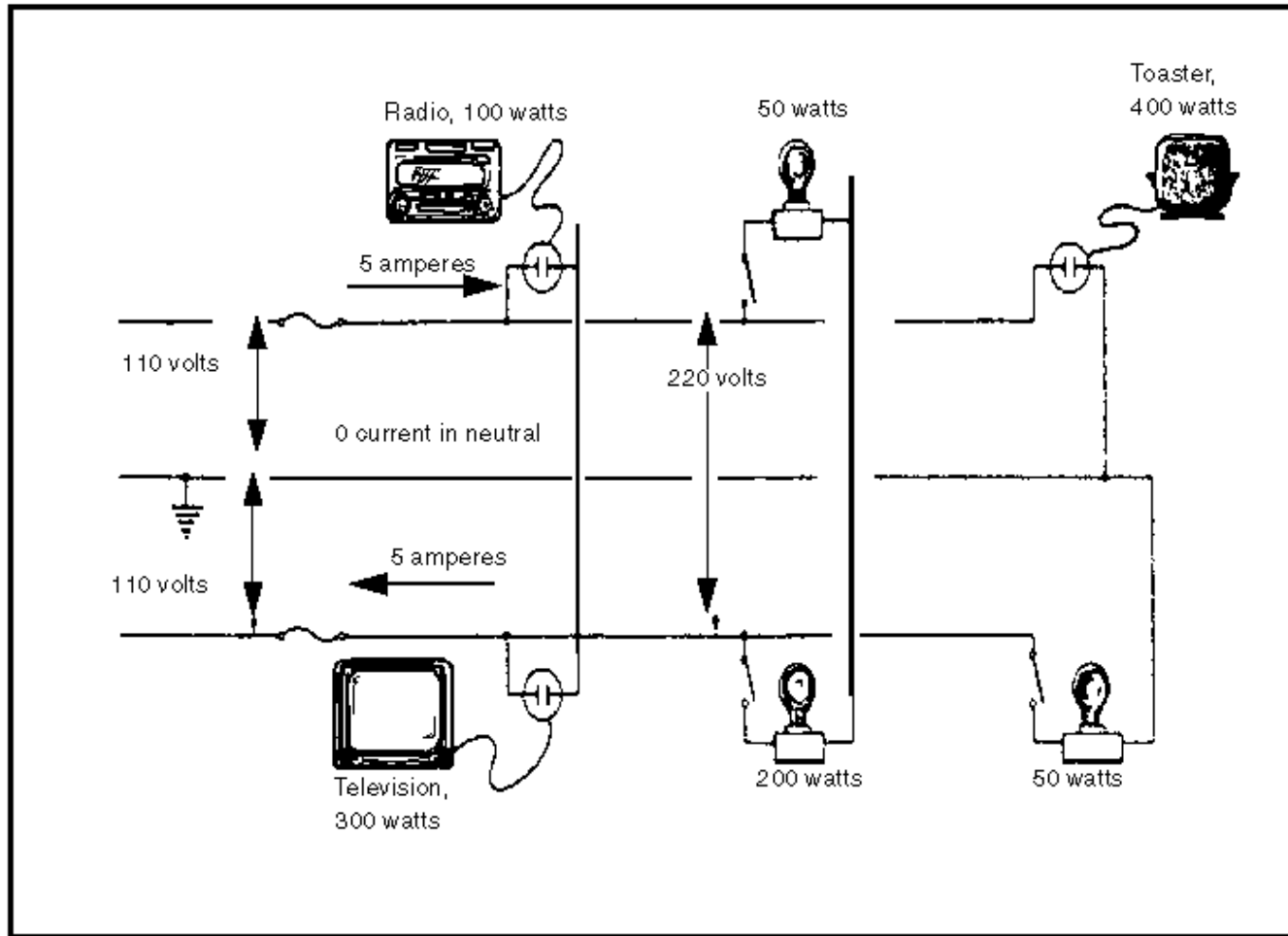

Figure 3-2. Circuit balancing

<http://www.globalsecurity.org/military/library/policy/army/fm/5-424/chap3.htm>

Allowing Split-Phase Electricity Distribution Propagation, With Amplification



Phase Coupling

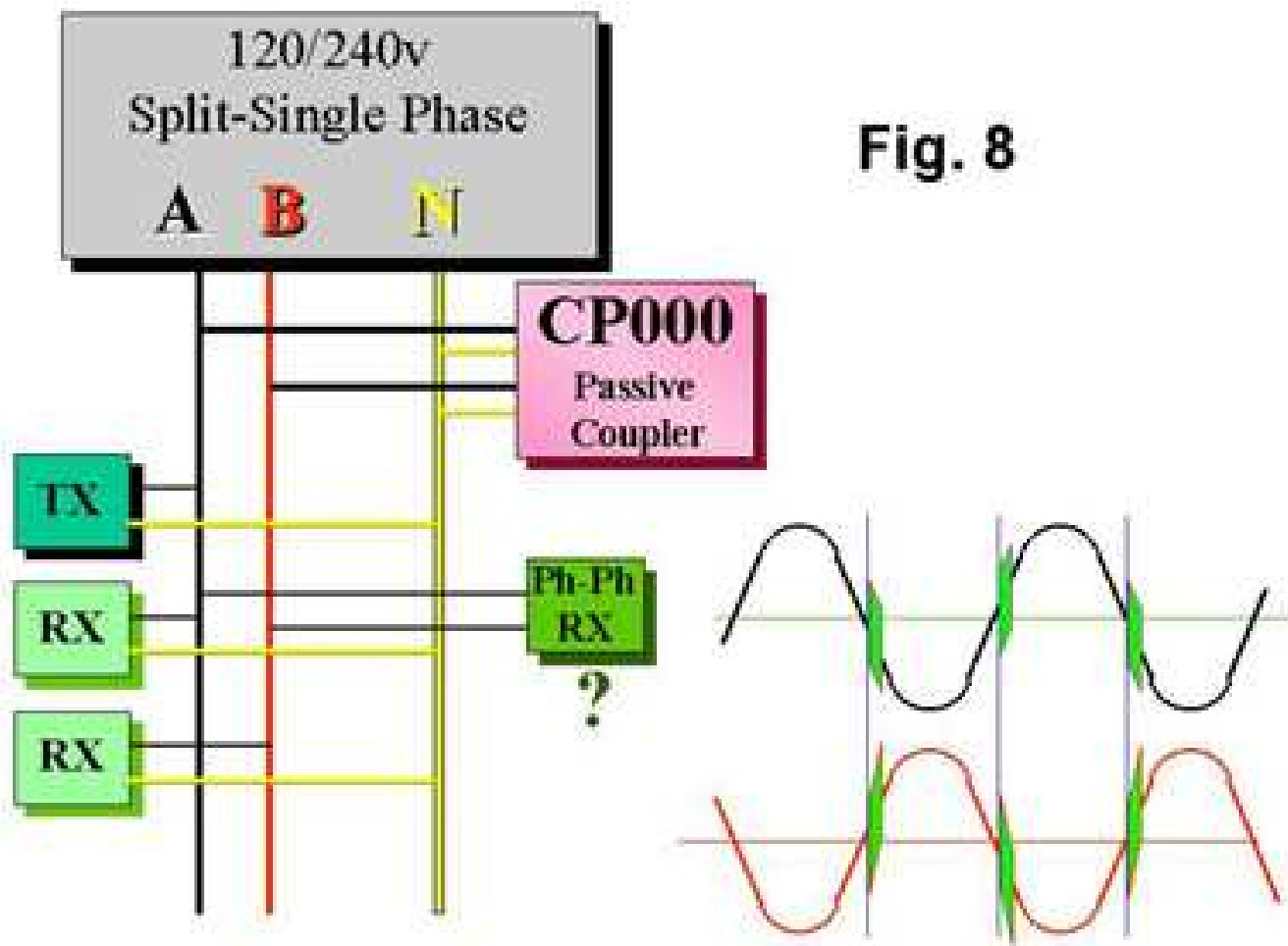

<http://www.hometoys.com/htinews/jun97/articles/kingery/kingery3.htm>

Reducing Line Noise



I need to use this because my UPS dampens X10 signals. You also might want to block X10 signals from coming into your house, or you can use unique house codes.

Home Application: First Floor

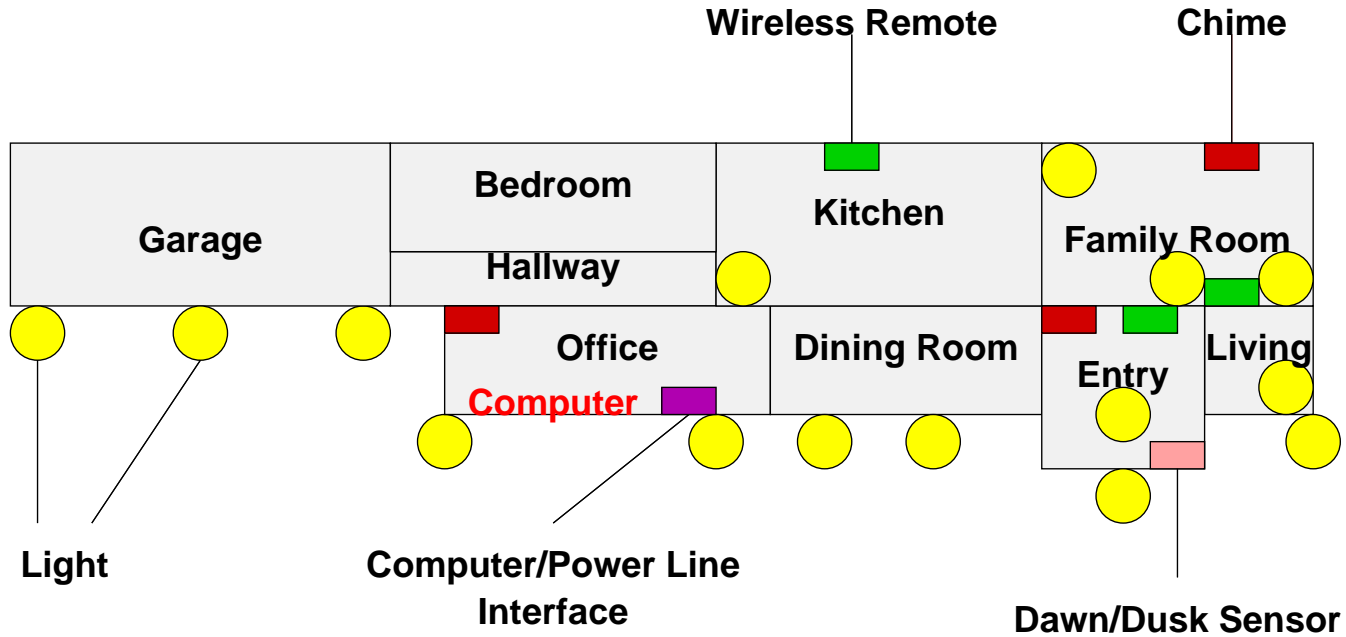

Home Application: Second Floor

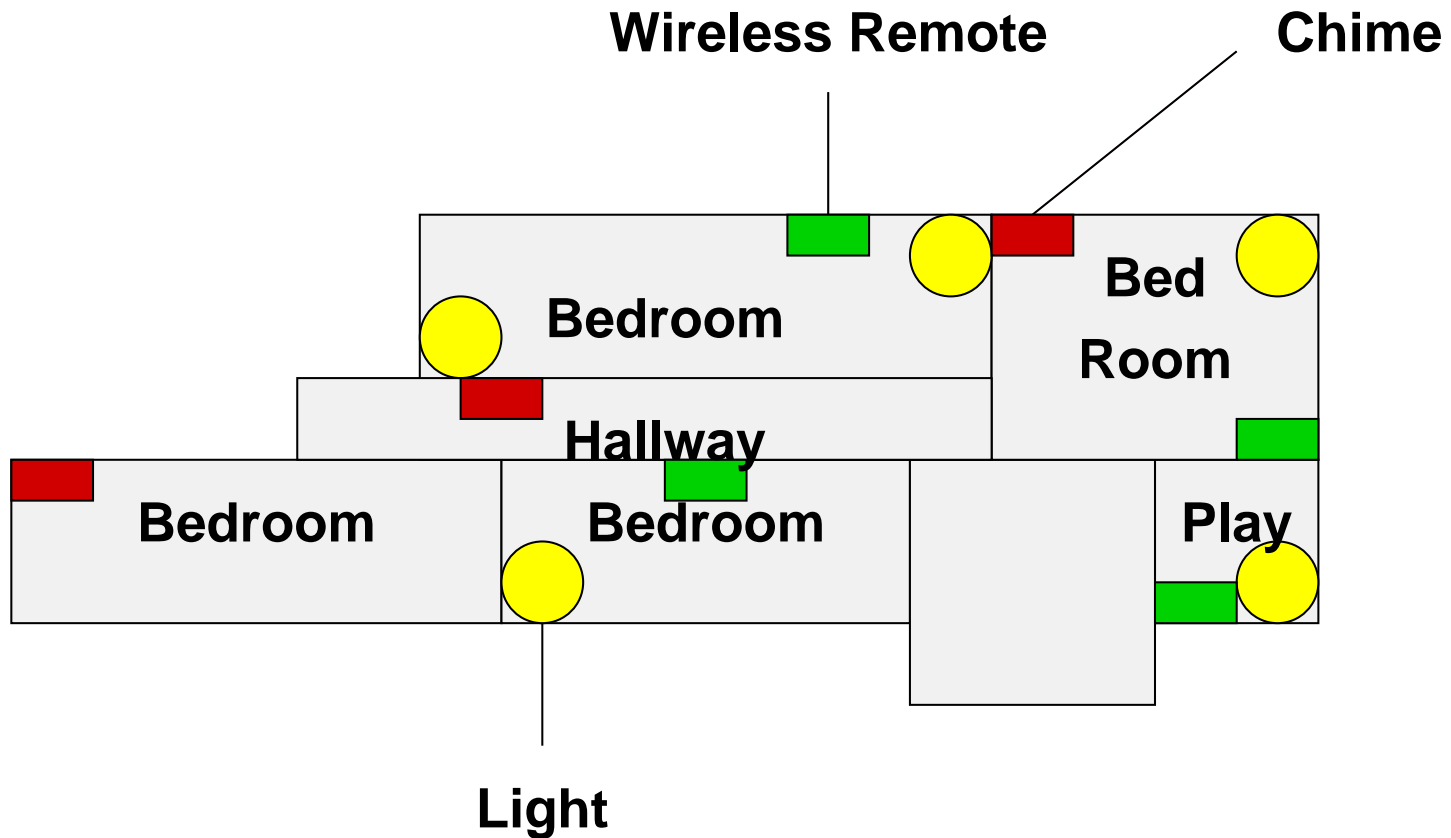

Wall Switch



Flat Switch



Three-Way Switch

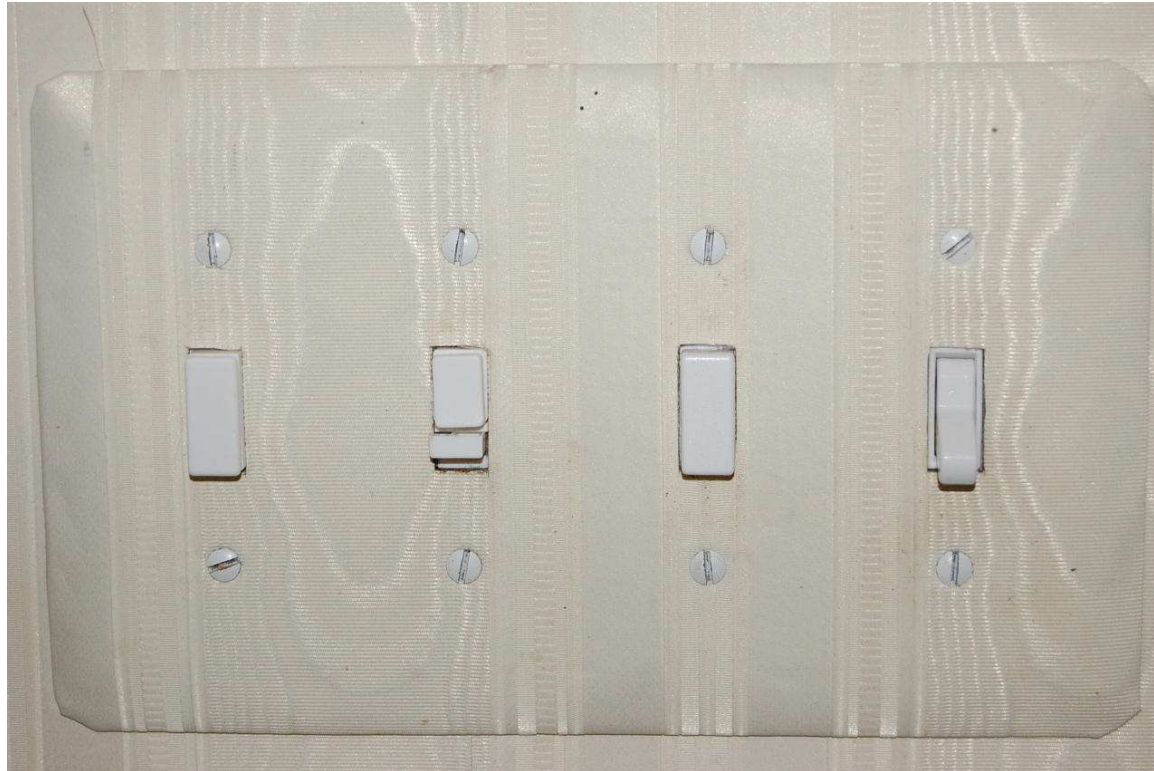

Three-way switches are difficult to install because the X10 detection module must be on the *power* side of the switch, not the ground side; see <http://www.hometoys.com/htinews/dec97/articles/kingery/kingery6.htm>.

Wireless Wall Switch



Wireless Receiver



Wireless Remote



Lamp/Appliance Control



Pool



The pool pump runs longer when the weather is warmer. The server gets the outside air temperature from a weather web site and turns the pool pump on and off at the proper times.

Heyu

NAME

heyu - control program for the X10 CM11A serial interface

SYNOPSIS

```
heyu address unit-specifier
heyu date
heyu erase
heyu function unit-specifier state
heyu info
heyu help
heyu monitor
heyu preset unit-specifier preset-dim
heyu reset [housecode]
heyu setclock
heyu status [unit-specifier]
heyu stop
heyu turn unit-specifier state [amount]
heyu upload [check]
heyu version
```

Cron

```
# on
0 10 * * *      root x10on christmas
0 12 * * *      root touch /u/x10/wait_for_dusk
0 14 * * *      root x10on bathroom
30 20 * * *     root x10on boyscolor catherine
# fade
30 21 * * *     root x10dim entrytable christmas bathroom
# off
0 21 * * *      root x10off bookcase
0 22 * * *      root frontlights off
0 23 * * *      root x10off tiffany
0 0 * * *       root x10off 'x10group 1 | egrep -v '^entrytable$''
0 0 * * *       root touch /u/x10/wait_for_dawn
0 1 * * *       root x10dimoff_slow laundry
# 2:01 for daylight savings
1 2 * * *       root x10alloff
```

Computer/Power Line Interface



Monitoring

```
7/6 at 05:40:49 address unit 8 : housecode d (entrymotion_dusk)
7/6 at 05:40:49 function      Off : housecode d unit 8 (entrymotion_dusk)
7/6 at 20:35:57 address unit 8 : housecode d (entrymotion_dusk)
7/6 at 20:35:57 function      On  : housecode d unit 8 (entrymotion_dusk)
7/6 at 22:05:46 address unit 3 : housecode f (catherine)
7/6 at 22:05:46 function      Off : housecode f unit 3 (catherine)
7/5 at 23:18:20 address unit 13 : housecode i (remotebed2)
7/5 at 23:18:21 function      Off : housecode i unit 13 (remotebed2)
```

Auto-Response to Activity

```
x10 monitor | while read LINE
do
    echo "$LINE" >>/var/log/x10
    case "$LINE" in
        *" Off : "*"(remotebed)"*)
            x10off $(x10group 1 | egrep -v '^entrytable$')
            ;;
        # is it dusk?
        *" On : "*"(entrymotion_dusk)"*)
            if [ -f /u/x10/wait_for_dusk ]
            then    rm /u/x10/wait_for_dusk
                   x10on 1
                   echo "x10on masterbath laundry" | at now +45 minutes
            fi
            ;;
        *" On : "*" (kitchen_chime"*)"*)
            say "We are ready to eat."
            daemon -cf sbplay bell.wav 50
            sleep 2
            ;;
    esac
done
```

Sample Application: Dusk

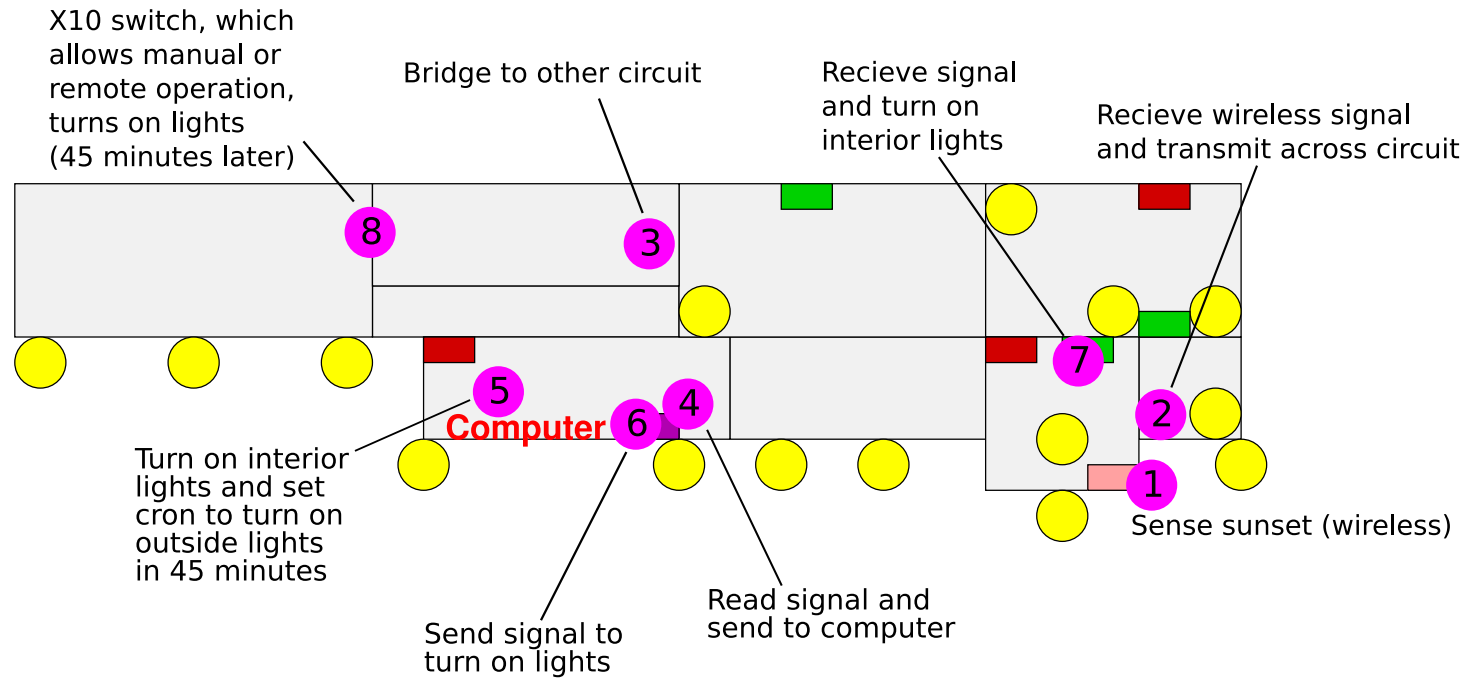

Telephone Interface



Telephone Logging

AT#CID=1

```
Wed Jul 8 21:34:00 EDT 2009 DATE = 0708
Wed Jul 8 21:34:00 EDT 2009 TIME = 2134
Wed Jul 8 21:34:00 EDT 2009 NMBR = 6107429657
Wed Jul 8 21:34:00 EDT 2009 NAME = PENNSYLVANIA
```

Lookup phone number in contact directory.

```
Wed Jul 8 21:34:04 EDT 2009 Bruce and
Christine Momjian from Bruce's cell phone (610) 742-9657
```

Optionally sound X10 chime if phone call is from an important phone number.

Telephone Dialing

Dial phone number from contact directory:

ATDT16107429657

Tue Apr 7 14:57:26 EDT 2009 16107429657 Bruce and
Christine Momjian to Bruce's cell phone

Family Suggestions

- Adding home automation changes your family's home environment
- Start slow; make incremental changes
- Accept that some home automation tasks are impossible
- You have succeeded when a family member asks for a home automation addition

Ideas

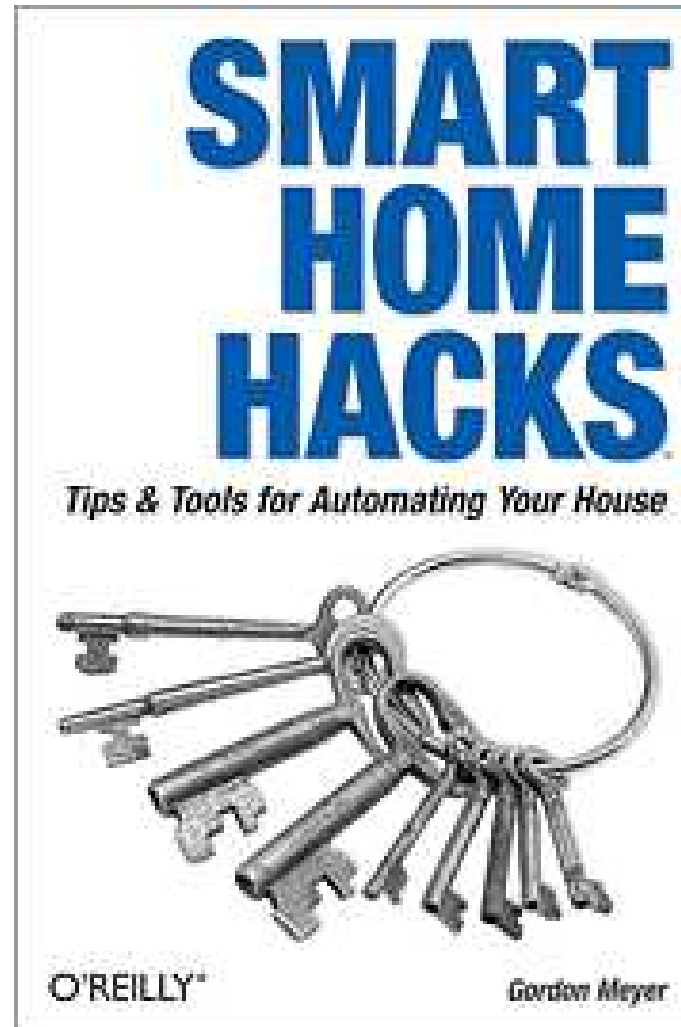

Conclusion

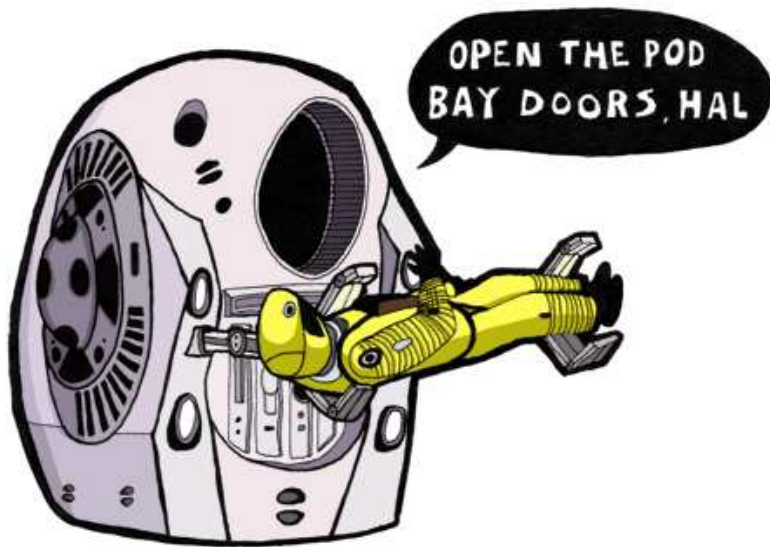

No!